

CUSTOMER: P/N: 3500.120AL REV. APPROVED BY:

REVISIONS		
REV.	DESCRIPTION	DATE
△		2015/04/22
△		2017/08/04
△		2020/05/05
△		2023/02/01
Change the specs of the safety wire, update the safety printing at the head and tail, and increase the spec label		

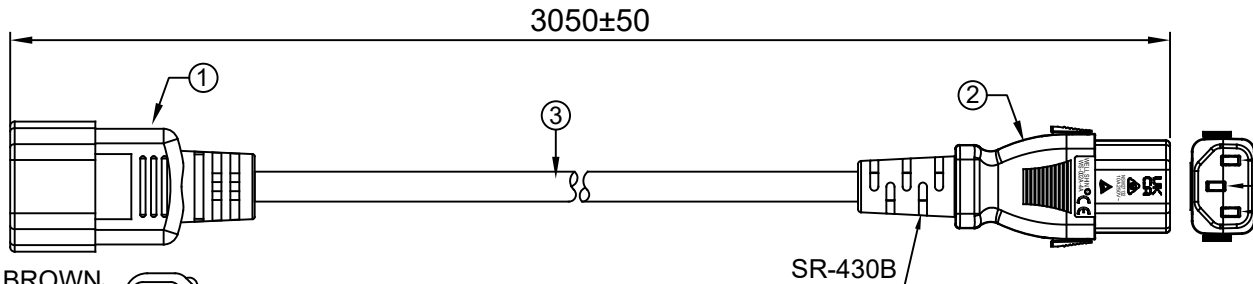

SR-430B

BROWN  
GRN/YEL  
BLUE

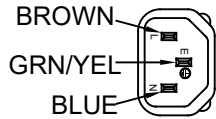

**MARKING:**

10A 250V~  
WELL SHIN  
WS-003  
UL US E115330

NSW18151  
BS EN 60320  
KM 38965

IEC-60320-C14

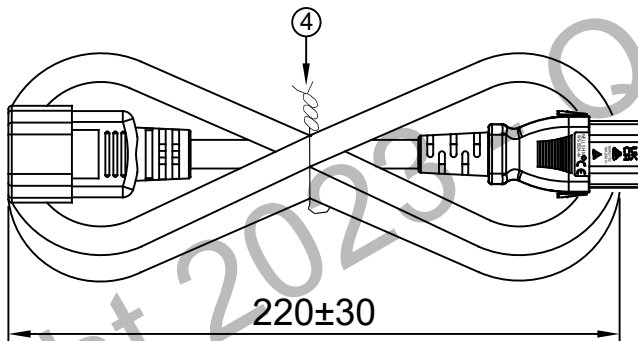

**MARKING:**

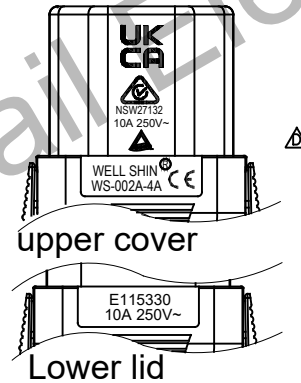

IEC-60320-C13  
AUTO-LOCK

**NOTES:**

1. RoHS shown on the carton

頭	尾	線種	線規	芯線數	溫度	顏色	總長度
WS-003	WS-002A-4A	SJTW+H05VV-F+60227 IEC53(RVV)	17AWG+1.0MMSQ	3G	105°C	BLACK	3050mm

MARKING: (M) FOR DONG-GUAN PLANT, (K) FOR KUN-SHAN PLANT

ITEM	DESCRIPTION	COLOR	QTY
④	Cable tie	CLEAR	1
③	SJTW 17AWG 3C 105°C + H05VV-F 3G 1.0MMSQ + 60227 IEC 53(RVV) 300/500 3G 1.0MMSQ APPROVAL: UL,CUL(CSA),EUROPEAN,CCC,RCM,CE	BLACK	1
②	WS-002A-4A 10(A) 250(V) APPROVAL: UL, CUL,RCM.TUV,UKCA,CE	BLACK	1
①	WS-003 10(A) 250(V) APPROVAL: UL, CUL,ENEC,RCM.BSI	BLACK	1

SIGNATURE		<b>QUAIL ELECTRONICS, INC.®</b> <a href="http://www.quail.com">http://www.quail.com</a>	
ENGINEER BY:			
MANAGER BY:		PRODUCT NO.:	DATE: 2023/01/03
CHECKED BY:		UNIT: mm	SHEET: 1 OF 1
DRAWN BY:		DWG NO: 0096-4926	
			REV. D